



VALVOLA ANTIURTO PILOTATA, ANTICAVITAZIONE,  
REGOLAZIONE UNICA

SINGLE CARTRIDGE DUAL CROSS OVER, ANTICAVITATION, PILOT OPERATED RELIEF

Tipo/Type:

A-VA/RU/P 150/..

3

19.00

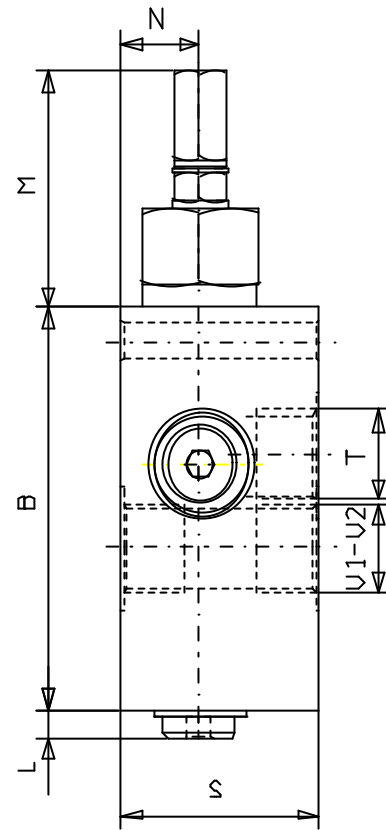
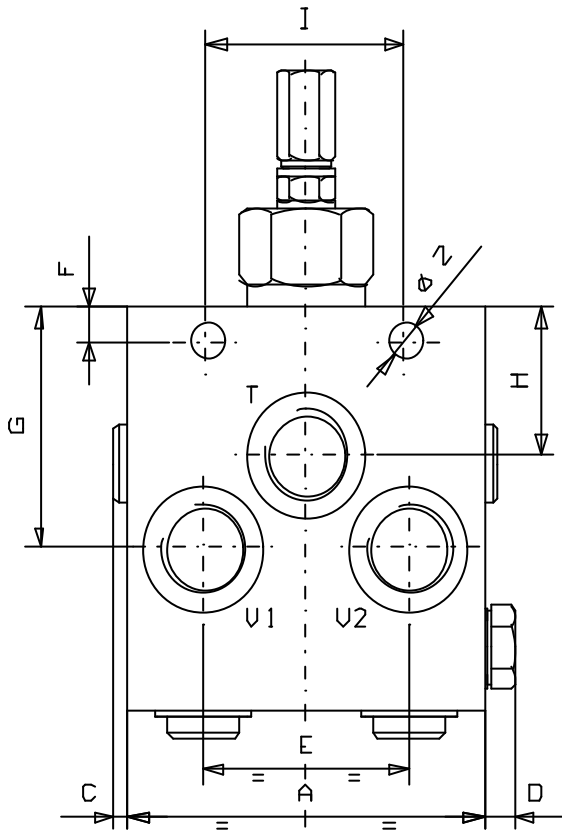

Filtraggio raccomandato:  
RECOMMENDED filtration level:  
18/14 ISD 4406  
(D NAS-143B)  
o migliore/or better.

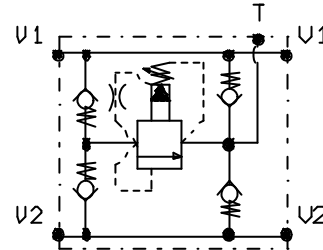
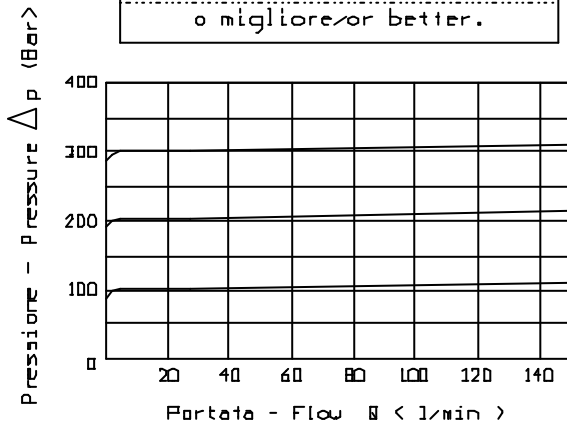

Press. max.  
( Bar )  
350

Portata max.  
( l/min )  
150

Collettori in acciaio  
Steel body

CODICE	V1-V2	T	A	B	C	D	E	F	G	H	I	L	M	N	S	Z	
A-VA/RU/P150/12	G1/2	G1/2	90	95	3.5	7.5	52	8	57	35	50	7	56	20	50	8.5	
A-VA/RU/P150/34	G3/4	G3/4	122	120	0	0	70	8.5	6x5	3x5	62	5	56	25	60	8.5	
A-VA/RU/P150/100	G 1	G3/4	146	134	0	0	70	7	6x5	3x5	34	72	0	56	25	60	8.5