



VALVOLA DI BILANCIAMENTO, SEMPLICE EFFETTO,
SERIE "TR"

PILOT ASSISTED, SERIES "TR" OVERCENTRE

Tipo/Type: A-VBSE/TR 38/VMP5

5

33.12

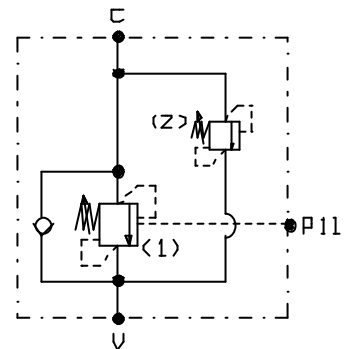
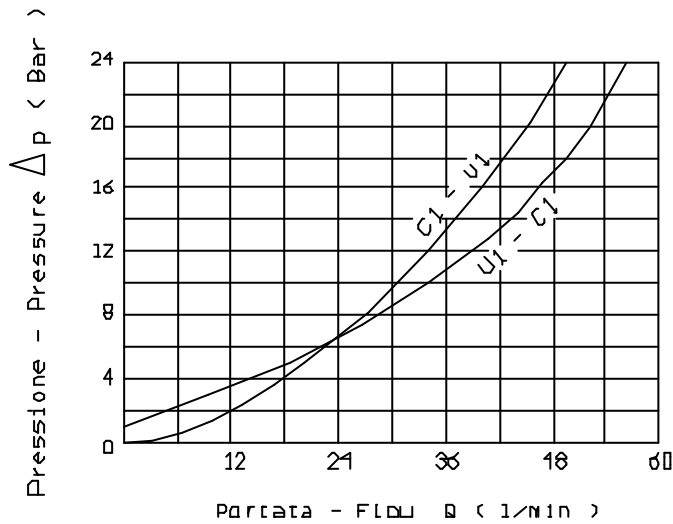
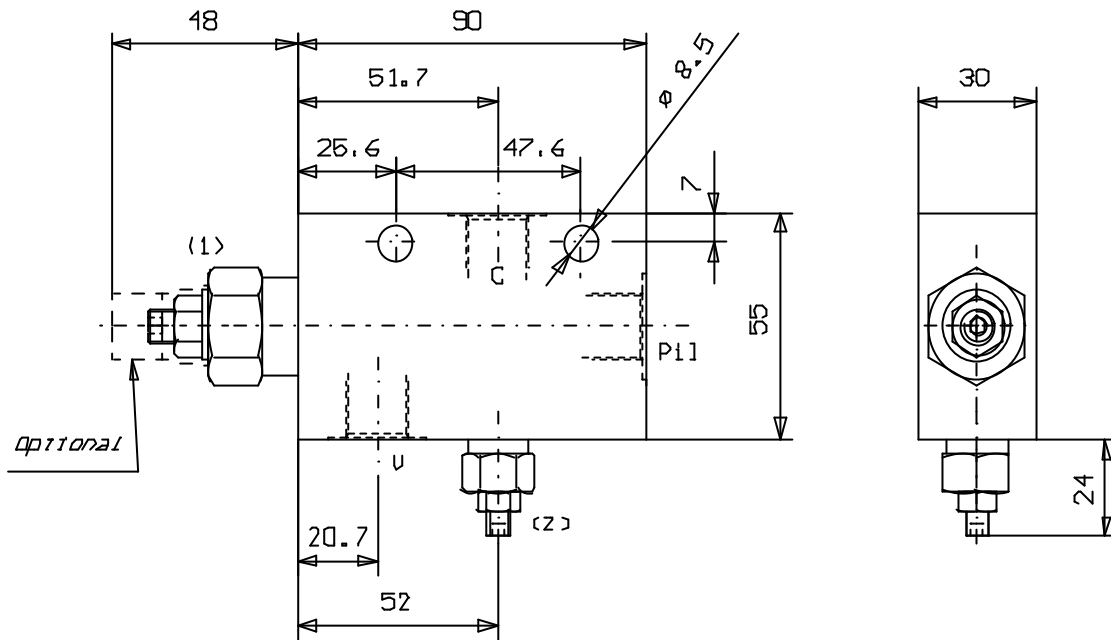

Rapp. Pilot.
4.2:1

Press. max. (Bar)
350

Portata max. (l/min)
40

ATTACCHI	
U - C	G 3/8
Pil	