



VALVOLA DI BILANCIAMENTO, SEMPLICE EFFETTO,
SERIE "TR", PILOT. INT., CON VALV. DI MAX PRESS.

PILOT ASSISTED, INTERNAL PILOT, FLANGEABLE, SERIES "TR" OVERCENTRE, WITH RELIEF VALVE

Tipo/Type: A-VBSE/TR/PI 38/VMP5

5

33.30

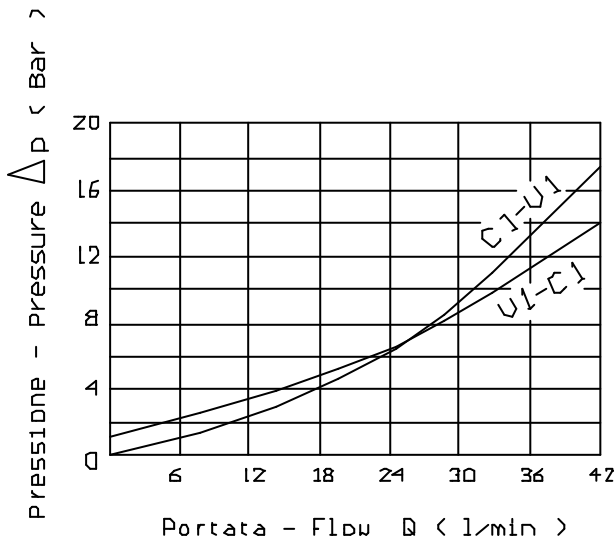
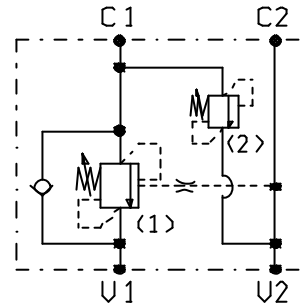
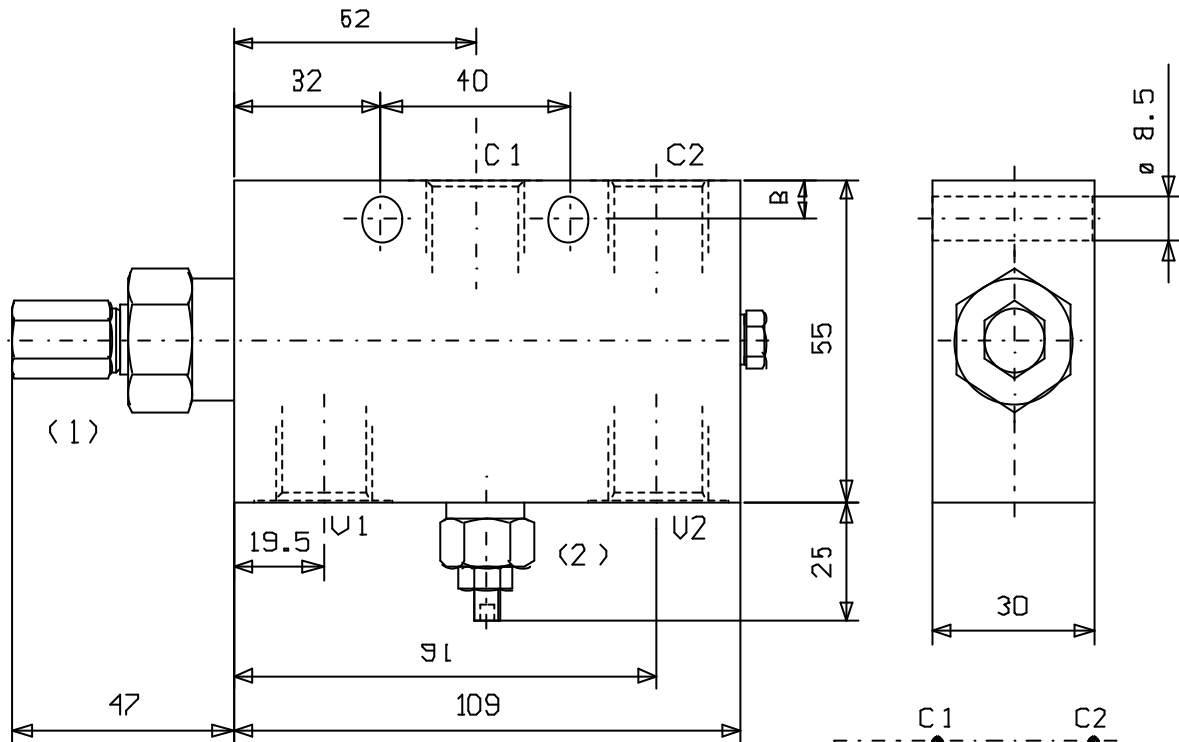

Press. max.
(Bar)
350

Rapp.
Pilot.
4.2:1

Collettore in acciaio
Steel body

| MOLLE Campo taratura Adj.press.range (bar) | |
|--|-----------|
| 1 | 100 - 350 |
| 2 | 200 - 400 |

| ATTACCHI | |
|----------|-------|
| U1 - U2 | G 3/8 |
| C1 - C2 | |