



VALVOLA DI BILANCIAMENTO, DOPPIO EFFETTO,
SERIE "TR"

DUAL PILOT ASSISTED, SERIES "TR" OVERCENTRE

Tipo/Type: A-VBDE/TR/IL 120

5

34.30

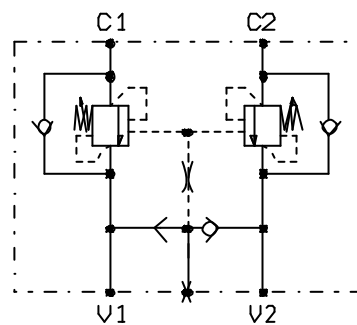
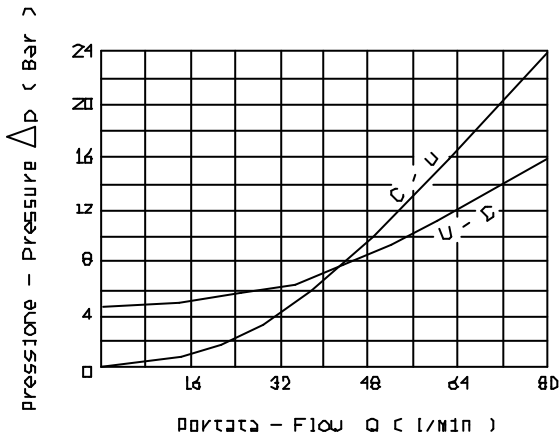
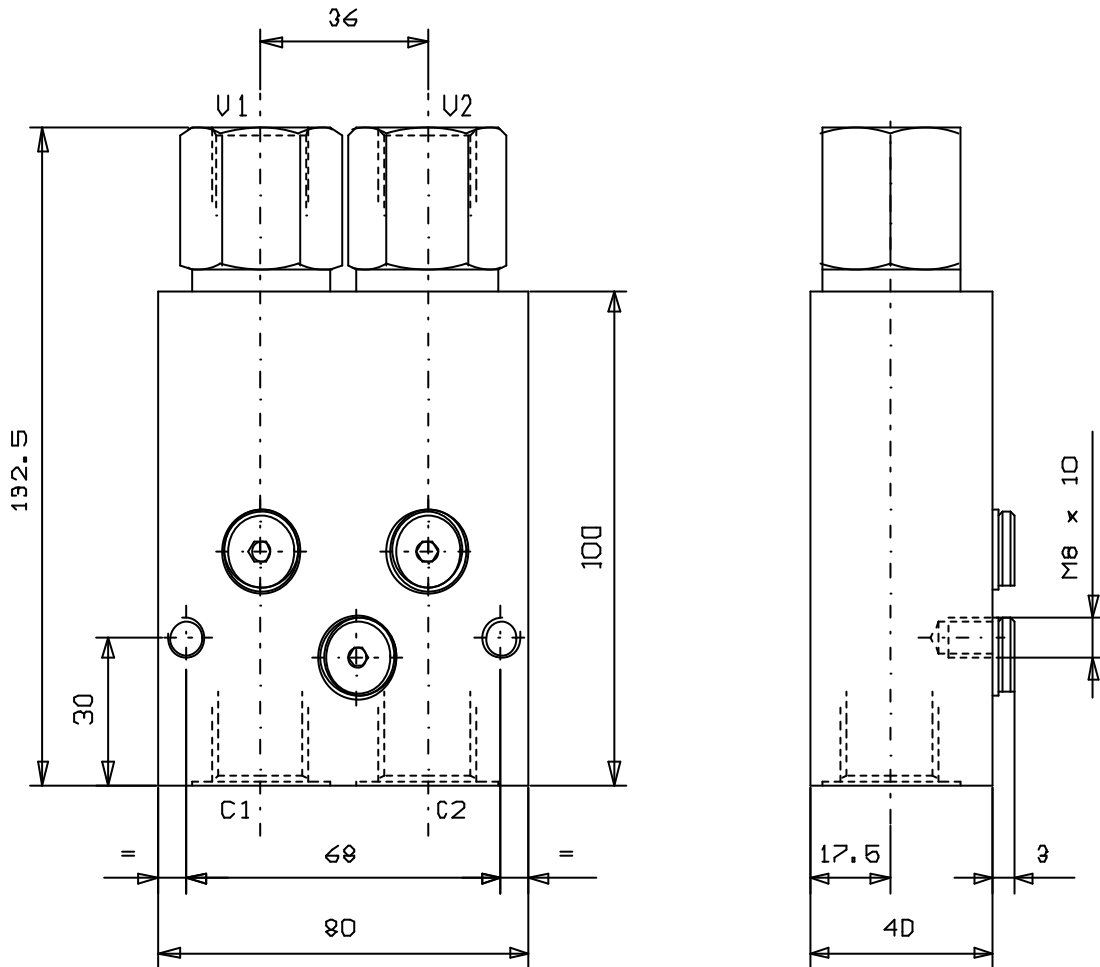

Collezione in acciaio
steel body

ATTACCHI	
U1 - U2	G 1/2
C1 - C2	

Rapp. Pilot.
4.2:1

Press. max. (Bar)
350

Portata max. (l/min)
80