



VALVOLA DI BILANCIAMENTO A CARTUCCIA
SERIE "TE", VERSIONE "CCP"

PILOT ASSISTED, CARTRIDGE TYPE, SERIES "TE" OVERCENTRE, "CCP" VERSION

Tipo/Type: VBSE/TE/C 150/CCP

5

41.00

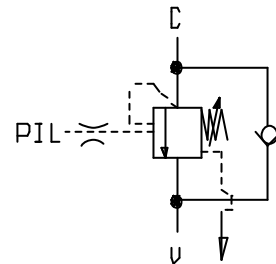
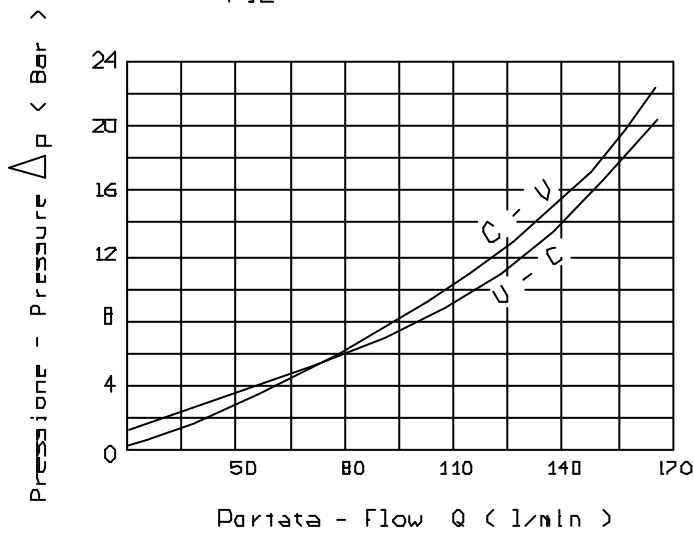
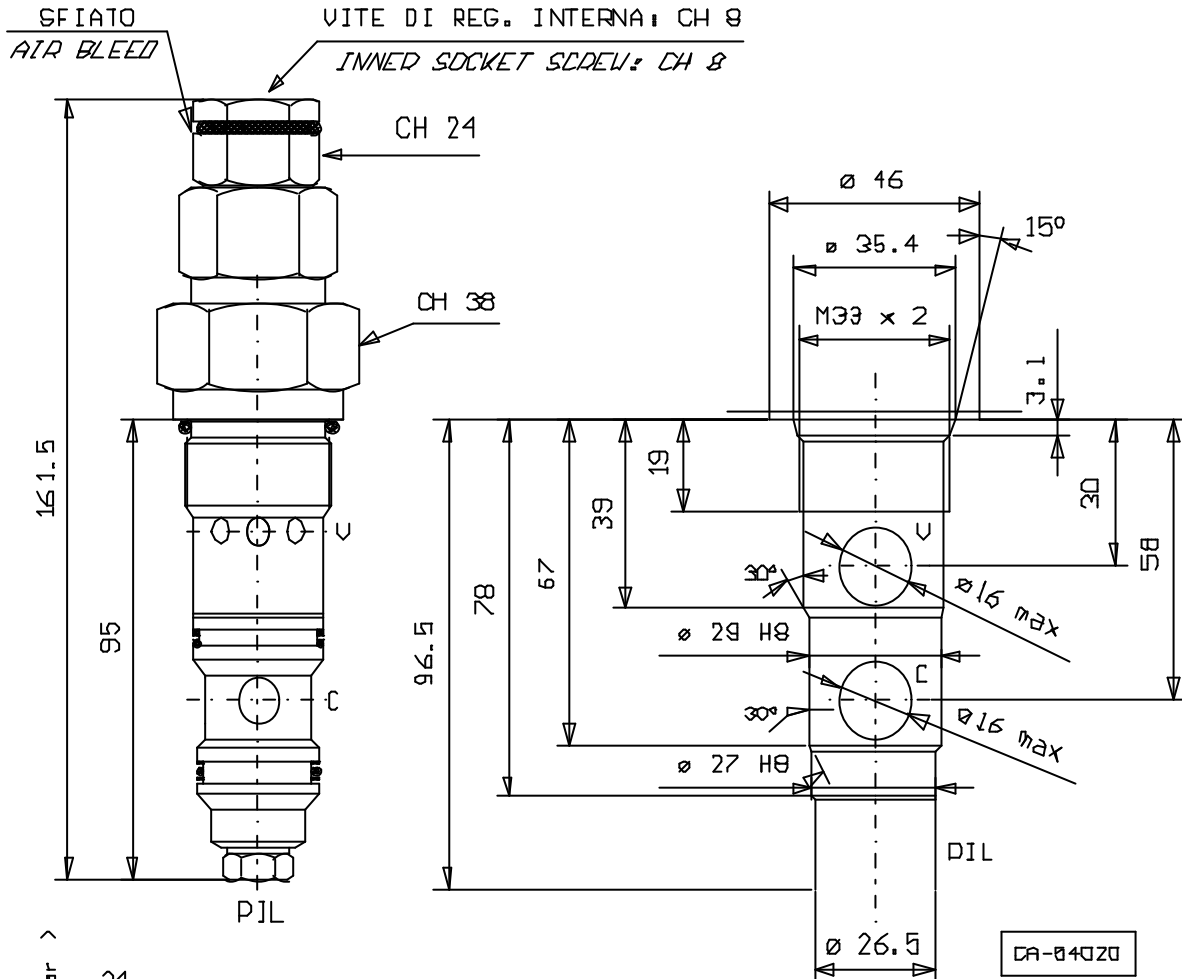

Press. max. (Bar)
350

Portata max. (l/min)
150

Coppia di serraggio Installation torque
200 - 225 (Nm)

Rapp. Pilot.	
STANDARD	4:1
A richiesta On request	8:1