



VALVOLA DI BILANCIAMENTO DOPPIA CON SBLOCCO FRENO  
 FLANGIABILE SU MOTORI CHAR-LYNN: SERIE "H"

DUAL OVERCENTRE VALVE, FACE MOUNTING, FOR CHAR-LYNN MOTORS: "H" SERIES  
 WITH BRAKE UNCLIPPING

Tipo/Type: VBDE/FL/CHL/H 120/SF

7

41.53

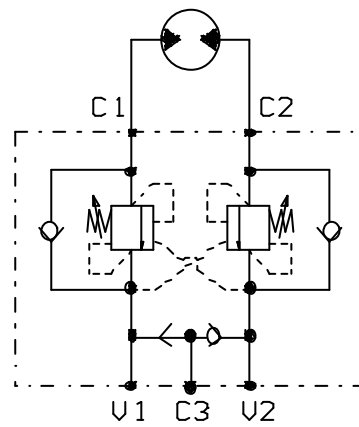
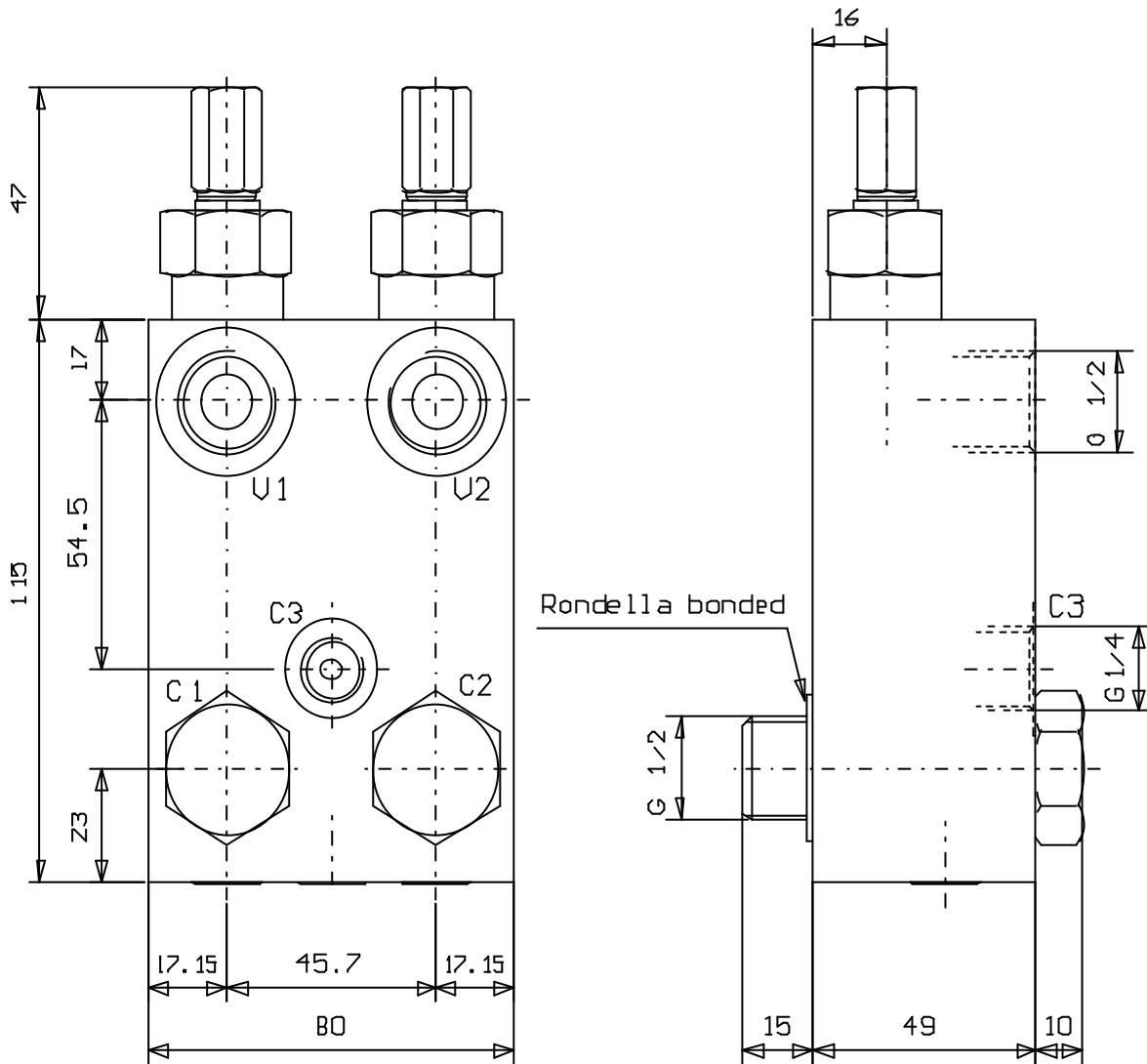

Rapp. Pilot.
4.2:1

Press. max. (Bar)
350

Portata max. (l/min)
50